

sampling solutions

Samplers can be chosen from standard or special (customised) for all possible sample points applicable for the product to be sampled and place in the process. Simple manual air-operation or semi- or fully automatized. From powder to granulates in food, feed, chemicals and recycling.

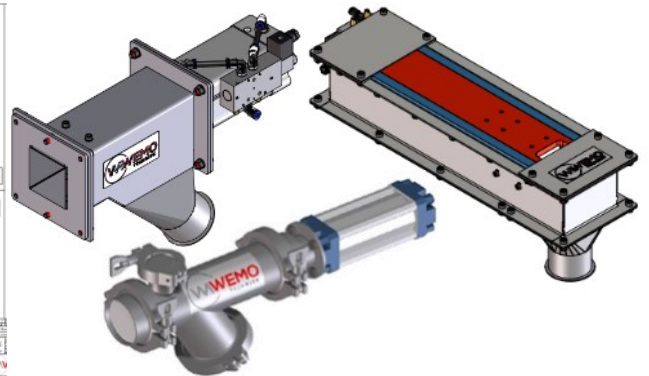
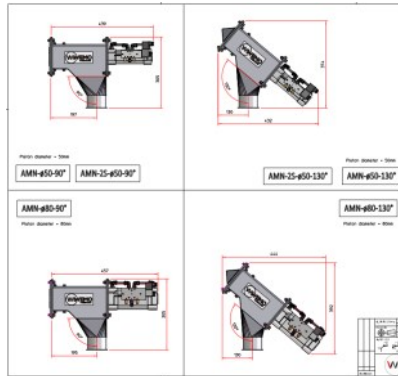

A sample can be collected in a container, in a plastic bag, manually or fully automatized. A variety of collectors, from a pipe, simple valve, a hand slide, visual transparent buffer station or directly in a sample container, all with or without product sensor detection, are available.

Multiple samples can be collected, using valves, directing samples to different buckets, or a carousel for multiple sample collection.

A carousel is semi-automatic. The next level is: fully automated sample bagging and labelling device.

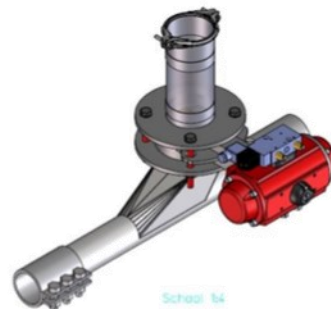
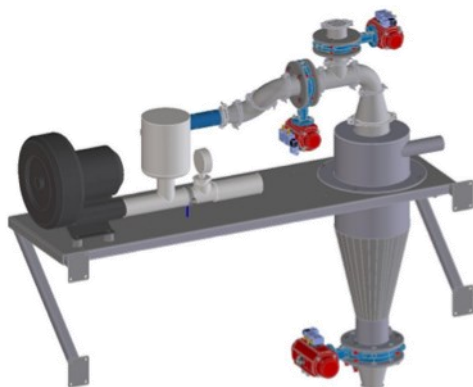
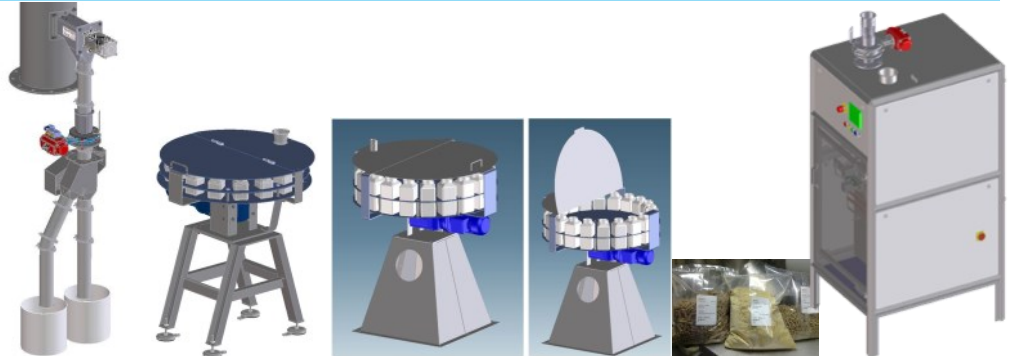

Multiple sample points for full control of your sampling for quality control, fully automatized with pneumatic vacuum transport system. Share your wishes with our sales and engineering team, we will make it possible.

Don't worry: is your typical solution not in this document?

We specialize in specials. For something completely different, we offer testing and engineering at affordable prices.

